

## SPECIFICATION

### FOR P/N MWB-6022-OP (General)

1.	Scope	This specification applies electret condenser microphone(E.C.M)
2.	Model No.	MWB-6022-OP (General)
3.	Operation Condition	
	3.1 Temperature	-20~+70℃
	3.2 Rel. Humidity	35%~85%RH
	3.3 Pressure	86~106KPa
	3.4 Environmental Noise	36dB(Maximum)
	3.5 Operation Voltage	+1~+10VDC
	3.6 Earth	⊖
4.	Electrical Characteristics	
	4.1 Standard Operation Voltage	+2.0VDC
	4.2 Impedance	2.2kΩ (Maximum)
	4.3 Current Consumption	0.6mA(Maximum)
	4.4 Sensitivity	(0dB=1V/0.1Pa,1KHz) -62 ± 2dB
	4.5 Directivity	Omni-directional
	4.6 S/N Ratio	40dB(Minimum)(A-Curve at 1KHz,0.1Pa)
	4.8 Test Temperature	20℃±2℃
	Test Rel. Humidity	45%~65%RH

4.7 Schematic Diagram

$C=1\ \mu\text{F}$   $R1=2.2\text{k}\Omega$

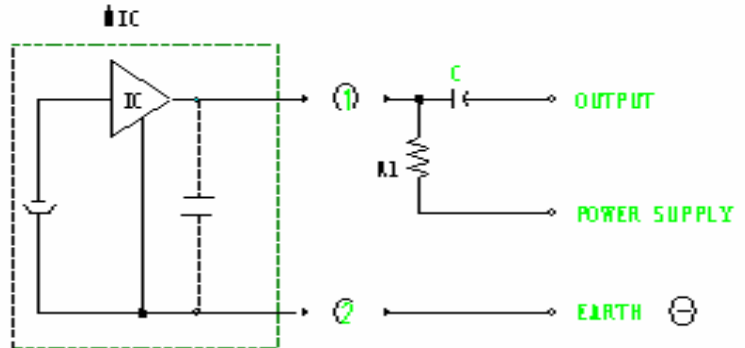

4.9 Frequency Response

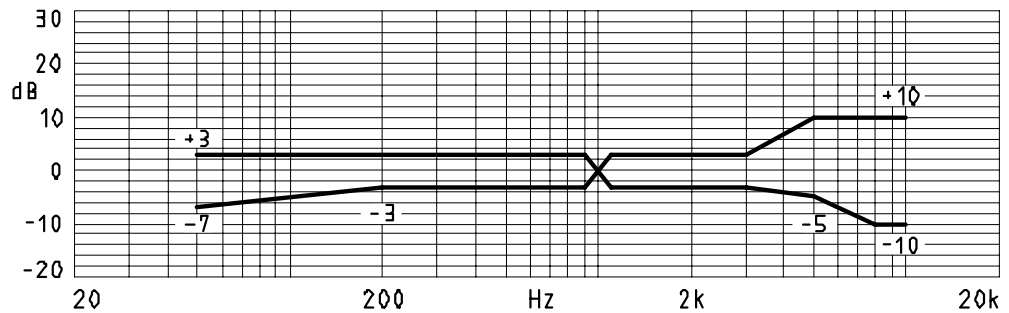

5. Mechanical Characteristics

5.1 Dimension  $\phi 6.0 \times 2.2$

5.2 Mass  $\leq 0.5\text{g}$

5.3 Dimensional Drawing

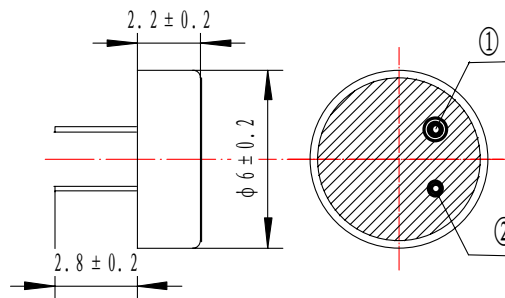

6.	<b>Reliability Tests</b> The sensitivity to be within $\pm 3\text{dB}$ of initial sensitivity after 3 hours of conditioning at $20^\circ\text{C}$ .	
6.1	Vibration	Frequency 1      10Hz~55Hz Amplitude $\pm 0.15\text{mm}$ Frequency 2      55Hz~150Hz Acceleration $20\text{m/s}^2$ Change of Frequency 1octave/min 2 hrs in each of 3 axes
6.2	Shocks	Pulse Shape        Half Sinusoidal Pulse Duration     11ms Acceleration $150\text{m/s}^2$ Number of Jolts    10 in each of 3 axes
6.3	Dry Heat/Cold	$70^\circ\text{C}$ for 72 hrs $-20^\circ\text{C}$ for 72 hrs
6.4	Damp Heat	90%RH, $+40^\circ\text{C}$ for 120 hrs
6.5	Temperature Cycles	$-20^\circ\text{C} \leftarrow \rightarrow 25^\circ\text{C} \leftarrow \rightarrow 70^\circ\text{C}$ (2h) (1h) (2h) (1h) (2h) 10cycles
7.	<b>Cautions</b>	
7.1	The soldering copper of a smaller type of less than 20W shall be applied.	
7.2	The temperature of the working surface of the soldering copper shall be below $270^\circ\text{C}$ .	
7.3	E.C.M shall be soldered fixed on the metal block (heat sink) which has the higher radiation effects. Said heat sink shall contact with each of E.C.M.	
7.4	The soldering time for each terminal shall be 1~2 sec.	
7.5	The pin hole soldering shall be avoided.	
7.6	E.C.M may easily destroyed by the static electricity, and the countermeasure for eliminating the static electricity (the ground for soldering copper, for worktable and for human body) shall be executed.	

WRTN	CHKD	APVD	DESCRIPTION